

QuickStand Series

Portable Presentation Screen for ProAV
www.elitescreens.com/quickstand



See our full product line at
www.elitescreens.com

QuickStand Series

- Portable Presentation Screen for ProAV
- QuickStand Portable Presentation Screen

FEATURES & BENEFITS

- Strong, lightweight and portable folding aluminum fixed-frame screen for multi-media conference/classroom presentations
- Standard Matte White (Gain 1.1) screen material
- Optional rear projection screen material (Gain 2.2)
- Sealed edge detachable frame design with material snap button attachments and corner pull cords to extend product life with prolonged use
- Easy setup and teardown design with no tools required
- Adjustable frame height can be raised or lowered at 8" increments for various presentations
- Lightweight and durable aluminum traveling case is wheeled for easy transport, storage and shipping for tradeshow and traveling presentations
- 150" plus-sized models come with AT legs for additional support
- Available in 72" to 200" diagonal sizes in 4:3 or 16:9 aspect ratio
- Drapery kit models also available
- Two year Manufacturer's parts & labor warranty



Standard AT Legs come with 150" and larger models.



Locking mechanism on the metal storage case ensures safety during the storage and shipping



Light weight and durable aluminum traveling case is wheeled for easy transport, storage and shipping



Aluminum frame connections ensure structural integrity with constant use.



Strong Corner-Guard provides additional protection during transport and storage



Choose either CineWhite Front Projection or Wraith Veil Rear Projection Material

See what the Experts said about CineWhite & CineGrey Material

"I found that it had a decent reflectivity to it, but didn't suffer too much from hot spotting (which obviously you would expect from a lower gain screen), nor did it have any sparkles or other anomalies to it. Elite certainly has a good idea here. Good performance, good build quality, and good features in a screen, for a lower price point.

AV Science, NY

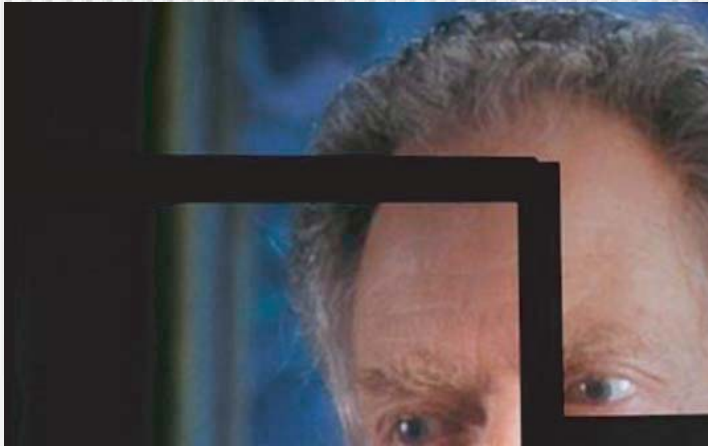

By comparison, the Firehawk[®] screen tends to reject ambient light from the side, a little better than the ezFrame by Elite. (All's fair - an equivalent Firehawk fixed wall projector screen is much over double the price. Color was virtually identical, but yellows did appear just a touch stronger than on the Firehawk[®]. This was very close and not an issue. Overall color was very good with a 100" 16:9 Elite ezFrame screen selling for about half of a Da-Lite Cinema Contour with ProTrim (their fancy flourish border), and barely a 1/3 of a Stewart Luxus Deluxe, it allows home theater people to own an attractive looking fixed wall screen, with good performance, at a price that simply isn't available from the larger established brands.

Art Feerman / Projectorreviews.com

QuickStand Series: Folding Screen, includes Aluminum Traveling Wheel Case

Model	Nominal Diagonal	View Height (in)	View Width (in)	View Height (cm)	View Width (cm)	UPS or FedEx	Net Weight (lbs)	Gross Weight (lbs)	Net Weight (kgs)	Gross Weight (kgs)	Packaging Dimension (LxHxW)	Gain	Screen Material	Drape Kit (Top/Sides/Bottom)
Q72V	72" (4:3)	43.5	58.0	109.9	147.3	Yes	23.2	57.5	10.5	26.1	42.3"x14.6"x13.5"	1.1	CineWhite	No
Q84V	84" (4:3)	50.3	67.0	127.0	170.2	Yes	59.0	69.3	26.8	31.4	53"x14.6"x13.5"	1.1	CineWhite	No
Q100V	100" (4:3)	60.0	80.0	152.4	203.2	Yes	62.3	74.8	28.3	33.9	53"x14.6"x13.5"	1.1	CineWhite	No
Q120V	120" (4:3)	72.0	96.0	182.9	243.8	Yes	66.1	75.0	30.0	34.0	53"x14.6"x13.5"	1.1	CineWhite	No
Q150V	150" (4:3)	90.0	120.0	228.6	304.8	Yes	89.3	101.4	40.5	46.0	62.5"x15.5"x15"	1.1	CineWhite	No
Q180V	180" (4:3)	108.0	144.0	274.3	365.8	Yes	99.2	112.4	45.0	51.0	72.4"x14.3"x14.3"	1.1	CineWhite	No
Q200V	200" (4:3)	120.0	160.0	304.8	406.4	Yes	137.8	149.9	62.5	68.0	51.2"x14.3"x18.3"	1.1	CineWhite	No
Q84VD	84" (4:3)	50.0	67.0	127.0	170.2	Yes	76.7	93.7	34.8	42.5	50.4"x17.9"x12.2"	1.1	CineWhite	Included
Q100VD	100" (4:3)	60.0	80.0	152.4	203.2	Yes	89.3	109.1	40.5	49.5	50.4"x17.9"x12.2"	1.1	CineWhite	Included
Q120VD	120" (4:3)	72.0	96.0	182.9	243.8	Yes	96.6	106.9	43.8	48.5	51.6"x18.7"x14.2"	1.1	CineWhite	Included
Q150VD	150" (4:3)	90.0	120.0	228.6	304.8	Yes	77.0	86.9	34.9	39.4	62.2"x18.7"x14.2"	1.1	CineWhite	Included
Q180VD	180" (4:3)	108.0	144.0	274.3	365.8	Yes	95.0	105.0	43.1	47.6	72.2"x20"x14.2"	1.1	CineWhite	Included
Q200VD	200" (4:3)	120.0	160.0	304.8	406.4	Yes	108.2	120.9	49.1	54.8	50.8"x18.5"x18"	1.1	CineWhite	Included
Q100HD	100" (16:9)	49.0	87.2	124.5	221.5	Yes	84.9	95.9	38.5	43.5	54.3"x18"x12.2"	1.1	CineWhite	Included
Q120HD	120" (16:9)	58.9	104.6	149.6	265.7	Yes	92.6	104.7	42.0	47.5	47"x18.7"x14.2"	1.1	CineWhite	Included
Q150HD	150" (16:9)	73.6	130.7	186.9	332.0	Yes	116.8	130.0	53.0	59.0	55.5"x18.7"x14.2"	1.1	CineWhite	Included
Q180HD	180" (16:9)	88.3	156.9	224.3	398.5	Yes	130.0	145.5	59.0	66.0	64"x18.7"x20"	1.1	CineWhite	Included
Q200HD	200" (16:9)	98.0	174.0	248.9	442.0	Yes	143.3	154.3	65.0	70.0	72"x18.7"x20"	1.1	CineWhite	Included



QuickStand Folding Screen 100" (Q100VD) shown with Standard Drape Kit

QuickStand Series Dimension Table

Model	Screen Diag. & Aspect Ratio	View Width (A)	View Height (B)	Left/Right Black Masking (A1)	Top/Bottom Black Masking (B1)	Overall Frame Width (A2)	Overall Frame Height (B2)	Overall Height (B3)	Stand Width (C)	Storage Case Dimensions		
										Height (D)	Length (D1)	Width (D2)
Q72V	72" (4:3)	1463.0	1097.3	76.0	76.0	1616.0	1250.0	1687.0	1040.0	225.0	980.0	235.0
Q84V	84" (4:3)	1707.0	1280.2	76.0	76.0	1862.0	1435.0	2300.0	1040.0	225.0	1160.0	235.0
Q100V	100" (4:3)	2032.0	1524.0	76.0	76.0	2187.0	1680.0	2800.0	1040.0	225.0	1160.0	235.0
Q120V	120" (4:3)	2438.4	1828.8	76.0	76.0	2584.0	1984.0	3300.0	1040.0	245.0	1190.0	285.0
Q150V	150" (4:3)	3048.0	2286.0	76.0	76.0	3203.0	2440.0	3500.0	1040.0	280.0	1460.0	285.0
Q180V	180" (4:3)	3657.6	2743.2	76.0	76.0	3810.0	2900.0	4000.0	1040.0	280.0	1715.0	285.0
Q200V	200" (4:3)	4064.0	3048.0	76.0	76.0	4220.0	3203.0	4300.0	1040.0	280.0	1170.0	380.0
Q72H	72" (16:9)	1594.0	897.0	76.0	76.0	1746.0	1049.0	2250.0	1040.0	225.0	1130.0	235.0
Q84H	84" (16:9)	1860.0	1046.0	76.0	76.0	2012.0	1198.0	2400.0	1040.0	225.0	1130.0	235.0
Q100H	100" (16:9)	2214.0	1245.0	76.0	76.0	2366.0	1397.0	2500.0	1040.0	225.0	1260.0	235.0
Q120H	120" (16:9)	2657.0	1494.0	76.0	76.0	2809.0	1646.0	3000.0	1040.0	245.0	1060.0	245.0
Q150H	150" (16:9)	3321.0	1868.0	76.0	76.0	3473.0	2020.0	3500.0	1040.0	280.0	1290.0	280.0
Q180H	180" (16:9)	3985.0	2242.0	76.0	76.0	4137.0	2394.0	3800.0	1040.0	280.0	1500.0	280.0
Q200H	200" (16:9)	4428.0	2491.0	76.0	76.0	4580.0	2643.0	4000.0	1040.0	280.0	1660.0	380.0

Unit: inch

Can't find size and ratio you're looking for? Visit elitescreens.com/csr to create your own

Model	Screen Diag. & Aspect Ratio	View Width (A)	View Height (B)	Left/Right Black Masking (A1)	Top/Bottom Black Masking (B1)	Overall Frame Width (A2)	Overall Frame Height (B2)	Overall Height (B3)	Stand Width (C)	Storage Case Dimensions		
										Height (D)	Length (D1)	Width (D2)
Q72V	72" (4:3)	57.6	43.2	3.0	3.0	63.6	49.2	66.4	40.9	8.9	38.6	9.3
Q84V	84" (4:3)	67.2	50.4	3.0	3.0	73.3	56.5	90.6	40.9	8.9	45.7	9.3
Q100V	100" (4:3)	80.0	60.0	3.0	3.0	86.1	66.1	110.2	40.9	8.9	45.7	9.3
Q120V	120" (4:3)	96.0	72.0	3.0	3.0	101.7	78.1	129.9	40.9	9.6	46.9	11.2
Q150V	150" (4:3)	120.0	90.0	3.0	3.0	126.1	96.1	137.8	40.9	11.0	57.5	11.2
Q180V	180" (4:3)	144.0	108.0	3.0	3.0	150.0	114.2	157.5	40.9	11.0	67.5	11.2
Q200V	200" (4:3)	160.0	120.0	3.0	3.0	166.1	126.1	169.3	40.9	11.0	46.1	15.0
Q72H	72" (16:9)	62.8	35.3	3.0	3.0	68.7	41.3	88.6	40.9	8.9	44.5	9.3
Q84H	84" (16:9)	73.2	41.2	3.0	3.0	79.2	47.2	94.5	40.9	8.9	44.5	9.3
Q100H	100" (16:9)	87.2	49.0	3.0	3.0	93.1	55.0	98.4	40.9	8.9	49.6	9.3
Q120H	120" (16:9)	104.6	58.8	3.0	3.0	110.6	64.8	118.1	40.9	9.6	41.7	9.6
Q150H	150" (16:9)	130.7	73.5	3.0	3.0	136.7	79.5	137.8	40.9	11.0	50.8	11.0
Q180H	180" (16:9)	156.9	88.3	3.0	3.0	162.9	94.3	149.6	40.9	11.0	59.1	11.0
Q200H	200" (16:9)	174.3	98.1	3.0	3.0	180.3	104.1	157.5	40.9	11.0	65.4	15.0

Unit: inch

Can't find size and ratio you're looking for? Visit elitescreens.com/csr to create your own

The listed measurements are for general reference only. Please contact Elite Screens to verify product design and dimensions before attempting to integrate its products with any structural or furniture modification. Although a manufacturer may offer product advice, it may be taken or disregarded at the integrator's discretion. Elite Screens will not be held responsible or be otherwise liable for faulty installations.

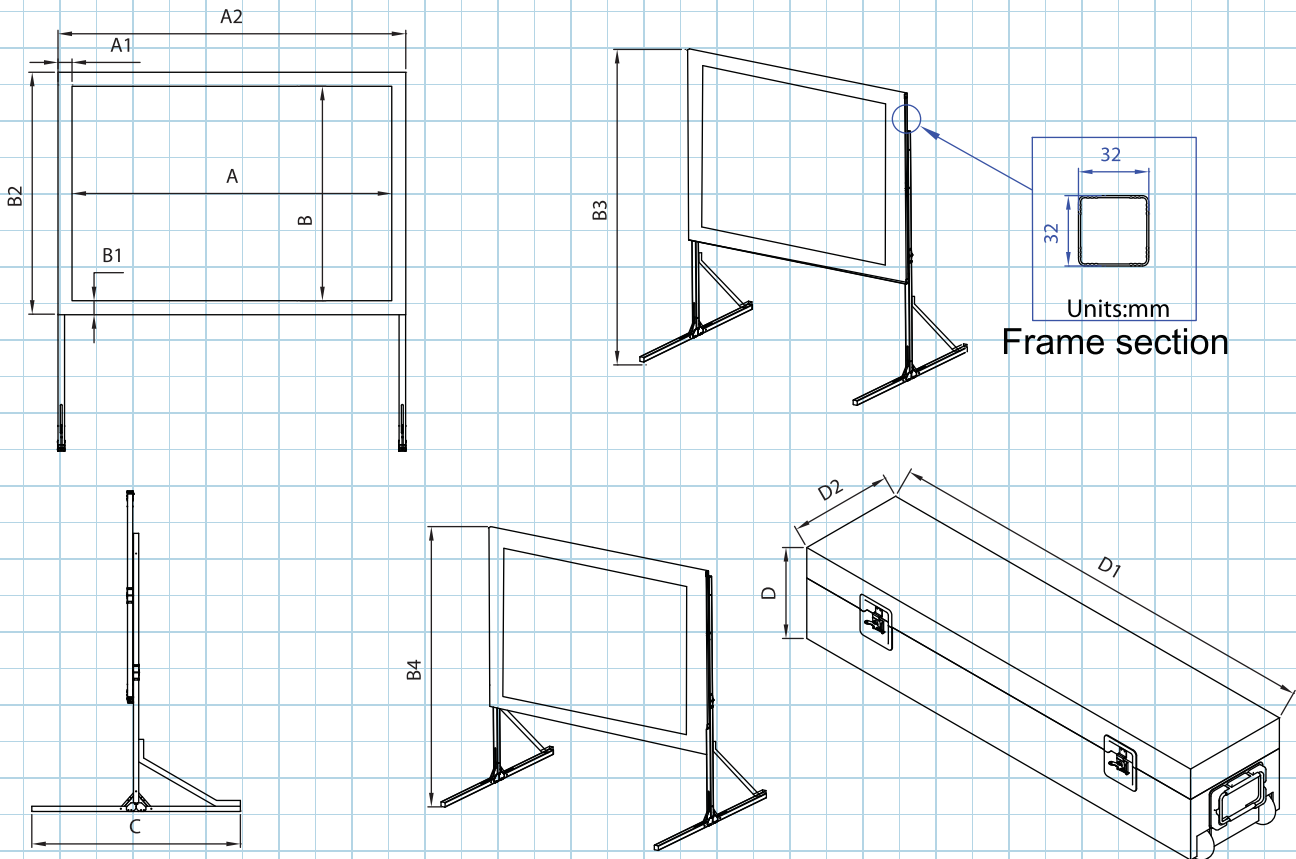

QuickStand Drape Series Dimension Table

Model	Screen Diag. & Aspect Ratio	View Width (A)	View Height (B)	Left/Right Black Masking (A1)	Top/Bottom Black Masking (B1)	Overall Width with Drape (A2)	A3	Max Height (B3)	Min. Height (B4)	Stand Width (C)	Storage Case Dimensions		
											Height (D)	Length (D1)	Width (D2)
Q84VD	84" (4:3)	1707.0	1280.2	76.0	76.0	1862.0	690.0	2680.0	1785.0	1040.0	1160.0	235.0	225.0
Q100VD	100" (4:3)	2032.0	1524.0	76.0	76.0	2187.0	690.0	3050.0	2250.0	1040.0	1160.0	235.0	225.0
Q120VD	120" (4:3)	2438.4	1828.8	76.0	76.0	2584.0	690.0	3800.0	2700.0	1040.0	1190.0	285.0	245.0
Q150VD	150" (4:3)	3048.0	2286.0	76.0	76.0	3203.0	690.0	4200.0	3265.0	1040.0	1460.0	285.0	280.0
Q180VD	180" (4:3)	3657.6	2743.2	76.0	76.0	3810.0	690.0	4450.0	3700.0	1040.0	1715.0	285.0	280.0
Q200VD	200" (4:3)	4064.0	3048.0	76.0	76.0	4220.0	690.0	4650.0	4060.0	1040.0	1170.0	380.0	280.0
Q100HD	100" (16:9)	2214.0	1245.0	76.0	76.0	2366.0	690.0	2500.0	1880.0	1040.0	1260.0	235.0	225.0
Q120HD	120" (16:9)	2657.0	1494.0	76.0	76.0	2809.0	690.0	3000.0	2820.0	1040.0	1060.0	245.0	245.0
Q150HD	150" (16:9)	3321.0	1868.0	76.0	76.0	3473.0	690.0	3500.0	3150.0	1040.0	1290.0	280.0	280.0
Q180HD	180" (16:9)	3985.0	2242.0	76.0	76.0	4137.0	690.0	3800.0	3150.0	1040.0	1500.0	280.0	280.0
Q200HD	200" (16:9)	4428.0	2491.0	76.0	76.0	4580.0	690.0	4000.0	3150.0	1040.0	1660.0	380.0	280.0

Unit: mm

Can't find size and ratio you're looking for? Visit elitescreens.com/csr to create your own

Model	Screen Diag. & Aspect Ratio	View Width (A)	View Height (B)	Left/Right Black Masking (A1)	Top/Bottom Black Masking (B2)	Overall Width with Drape (A2)	A3	Max Height (B3)	Min. Height (B4)	Stand Width (C)	Storage Case Dimensions		
											Height (D)	Length (D1)	Width (D2)
Q84VD	84" (4:3)	67.2	50.4	3.0	3.0	73.3	27.2	105.5	70.3	40.9	45.7	9.3	8.9
Q100VD	100" (4:3)	80.0	60.0	3.0	3.0	86.1	27.2	120.1	88.6	40.9	45.7	9.3	8.9
Q120VD	120" (4:3)	96.0	72.0	3.0	3.0	101.7	27.2	149.6	106.3	40.9	46.9	11.2	9.6
Q150VD	150" (4:3)	120.0	90.0	3.0	3.0	126.1	27.2	165.4	128.5	40.9	57.5	11.2	11.0
Q180VD	180" (4:3)	144.0	108.0	3.0	3.0	150.0	27.2	175.2	145.7	40.9	67.5	11.2	11.0
Q200VD	200" (4:3)	160.0	120.0	3.0	3.0	166.1	27.2	183.1	159.8	40.9	46.1	15.0	11.0
Q100HD	100" (16:9)	87.2	49.0	3.0	3.0	93.1	27.2	98.4	74.0	40.9	49.6	9.3	8.9
Q120HD	120" (16:9)	104.6	58.8	3.0	3.0	110.6	27.2	118.1	111.0	40.9	41.7	9.6	9.6
Q150HD	150" (16:9)	130.7	73.5	3.0	3.0	136.7	27.2	137.8	124.0	40.9	50.8	11.0	11.0
Q180HD	180" (16:9)	156.9	88.3	3.0	3.0	162.9	27.2	149.6	124.0	40.9	59.1	11.0	11.0
Q200HD	200" (16:9)	174.3	98.1	3.0	3.0	180.3	27.2	157.5	124.0	40.9	65.4	15.0	11.0

Unit: inch

Can't find size and ratio you're looking for? Visit elitescreens.com/csr to create your own

The listed measurements are for general reference only. Please contact Elite Screens to verify product design and dimensions before attempting to integrate its products with any structural or furniture modification. Although a manufacturer may offer product advice, it may be taken or disregarded at the integrator's discretion. Elite Screens will not be held responsible or be otherwise liable for faulty installations.

