

Installation/Operating Instructions

220V Targa Electric Projection Screen by Draper

These Installation/Operating Instructions are available in the official language of the country where you purchase the product. Please contact your distributor to request a copy.

Vous pourriez demander les instructions d'installation et d'opération traduites dans la langue officielle du pays où vous achetez le produit. Veuillez demander à votre distributeur.

Die Gebrauchsanweisung für Installation und Konstruktion sind in der offiziellen Sprache des Landes, indem Sie das Produkt gekauft haben, vorhanden. Fragen Sie die jeweilige Verkaufs-Abteilung.

⚠ Caution

- ① Read instructions through completely before proceeding.
 - ② Follow instructions carefully. Installation contrary to instructions invalidates warranty.
 - ③ Screen should be accessible for complete removal should fabric become damaged or should other service be required.
 - ④ Screen should be installed level (using a carpenter's level).
 - ⑤ Nothing should be fastened to screen dowel or viewing surface.
 - ⑥ Operating switch(es) packed separately in screen carton. Do not discard with packing material.
 - ⑦ Screen operates on 220V AC, 50 Hz., 1 ph. current.
- NOTE:** Screen has been thoroughly inspected and tested at factory and found to be operating properly prior to shipment.

Hanging Screen

General: When locating viewing surface and checking clearance for screen's operation, remember surface is centered in case. Handle case carefully to protect its finish.

Regardless of mounting method, screen should be positively and securely supported so that vibration or even abusive pulling on the viewing surface will not cause case to work loose or fall. Installer must insure that fasteners used are of adequate strength and suitable for the mounting surface chosen.

Suspended Installation:

Suspend screens from holes in endcaps as shown. S-hooks, chains (or cable) and turnbuckles should be provided by installer. "S" hooks should go through the front holes on the endcaps (see drawing on page 2), and both ends of the "S" hooks should be crimped for additional safety. Chains should be attached to beams or other structural members. Turnbuckles should be adjusted so screen hangs level.

Wall Installation:

Mount screen through holes in back of endcaps as shown. Installer should furnish screws, toggle bolts, molly bolts, nylon or lead anchors as required.

Wall Installation with 15 cm Extension Brackets:

Mount the brackets (not included with screen—see diagram below right) using hardware recommended for "Wall Installation" (above). Then, suspend the screen from the front holes with "S" hooks (as in "Suspended"). For added safety, crimp both ends of the "S" hooks so the screen cannot come off. For a more rigid installation, mount the screen from the back holes to the front of the bracket by using the screws and nuts provided with the brackets.

Recessed Installation:

Recess should permit access for removal of screen if necessary. Screen may be mounted as in suspended or wall installation. Optional Ceiling Opening Trim Kit available; see diagrams below and on page 2, and separate instruction sheet (included with Ceiling Opening Trim Kit).

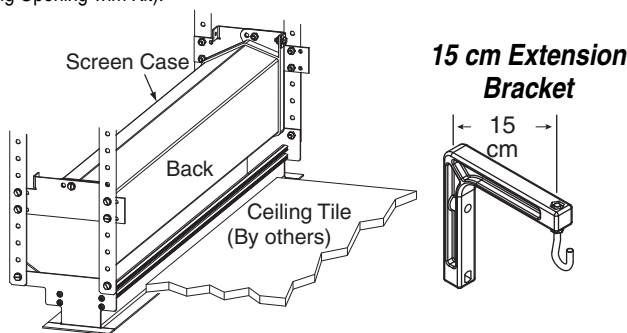

Electrical Connections

Screen operates on 220V AC, 50 Hz., 1 ph. current.

Junction box is located inside left endcap and cover plate is secured to endcap with two screws. Junction box contains brown, black and blue pigtail leads and green internal ground wire, per wiring diagram on reverse.

Screen is shipped with internal wiring complete and control switch (es) fully boxed. Wire connecting screen to switch (es) and switch (es) to power supply should be furnished by installer. Connections should be made in accordance with wiring diagram supplied, and wiring should comply with national and local electrical codes.

All operating switches should be "Off" before power is connected.

DRAPER®

411 S. Pearl St., Spiceland, IN 47385 USA ■ +1 765-987-799

www.draperinc.com ■ fax +1 765-987-1689

Copyright © 2010 Draper Inc. Form Targa220V_Inst10-R Printed in U.S.A.

Operation

Before operating screen remove tape securing fabric and dowel to roller. If viewing surface hangs out of case 22 or 23 mm, tape has probably been broken by rough handling in shipment, allowing surface to "unwrap" one turn about the roller. Manually wrap fabric back around roller without turning the roller itself.

Note: Drive unit contains a thermal overload protector. Operation as frequently as six cycles per hour may trip the protector. If tripped, the protector should reset automatically within a few minutes.

220V AC Single Station Control—3-position up-off-down switch permits operation to be stopped at any point. Factory adjusted limit switches automatically stop screen when fully down or fully up.

220V AC Multiple Station Control (Not CE approved)—Switches are similar in appearance to 220V Single Station Control. Screen stops when switch is released and may be restarted in either direction. Factory adjusted limit switches stop screen automatically when fully up or fully down.

24V Control—Three-button up-stop-down switch(es) stop at any point desired, operate in any sequence. Factory adjusted limit switches automatically stop screen when fully up or fully down. Installer should incorporate an all-pole disconnect in the fixed wiring.

Key Operated Switching (Not CE approved)—Two kinds of key-operated switches are optionally available with this unit. ① The key-operated power supply switch controls power to the screen and switches. When it is "off", the switches will not operate screen. Key may be removed from the switch in either "on" or "off" position. ② A three-position key switch permits the screen to be operated directly by key. In this case, the screen's operator must always have a key.

RS232/Ethernet—Serial communication and network communication optionally available with wall switches, RF or IR remote.

Plug & Play™—Provided with handheld IR remote control transmitter and 3m cord.

No wiring necessary except to connect to RS232. Screen is equipped with a handheld remote or 3-position operating switch (see below). Three positions (up-off-down) permit operation to be stopped at any point. Factory adjusted limit switches automatically stop screen when fully down or fully up.

Adjustments

Tools needed: Flashlight, small flathead screwdriver/Allen wrench (4mm or 5/32").

Screen settings have been factory set as ordered and should not normally require further adjustment. However, if you find it necessary to adjust for more or less viewing area, proceed as follows.

⚠ CAUTION: Always be prepared to shut screen off manually when new adjustment is being tested. Screen may be severely damaged if viewing surface is allowed to run too far up or too far down. When running up, the dowel should never wrap over the roller. When run to the down limit, a minimum of 1¼ wraps of fabric must remain on the roller.

The motor limit screws are normally located on the audience left of screen roller, and the viewing surface rolls off the back of the roller. If the viewing surface is coming off the front of the roller (motor on left), or the motor is on the audience right of the screen roller (with viewing surface rolling off the back), reverse the below instructions.

"DOWN" LIMIT ADJUSTMENT

To Reduce Screen Drop

- ① Raise screen surface about 30 cm above desired setting and turn off.
- ② Turn the DOWN limit screw (I) clockwise (three screw turns = ½ roller revolution).
- ③ Test by running screen down and repeat steps 1 and 2 until desired position is reached.

To Increase Screen Drop

- ① Run screen to the down limit.
- ② With the down switch on, turn the DOWN limit screw (I) counterclockwise (three turns of screw equals ½ roller revolution) to increase drop.
- ③ Test by running screen up about 1' and back down to new down limit.
- ④ Repeat steps 2 and 3 until desired position is reached.

⚠ CAUTION: At least 1¼ wraps of fabric must remain on the roller when screen is at the down limit!

"UP" LIMIT ADJUSTMENT

Screen is Running Too Far Up

- ① Lower screen surface about 30 cm below desired setting and turn off.
- ② Turn the UP limit screw (II) clockwise (three screw turns = ½ roller revolution).
- ③ Test by running screen up.
- ④ Repeat steps 1 through 3 until desired position is reached.

Screen Needs to Run Up More

- ① Run screen down about 1' and turn off.
- ② With the up switch on, turn the UP limit screw (II) counterclockwise (three turns of screw equals ½ roller revolution).
- ③ Repeat steps 1 and 2 until desired position is reached.

⚠ CAUTION: Do NOT allow the dowel to wrap up over the roller when the screen is running up! This could damage the screen.

Limit Adjustments (Built-in Low Voltage Motors)

- ① Connect the ILT switch to the motor via the terminal blocks, or via the modular port using four conductor modular cable. When using modular cable, the cable connectors MUST NOT be crimped in reverse, as with standard telephone cable.
- ② Set the slide switch to the lower position. Press and hold the DOWN button on the switch to move the viewing surface to the desired lower limit. If the screen moves in the opposite direction, release the DOWN button and press and hold down the STOP button for four seconds. This will reverse the operation of the UP and DOWN switches.
- ③ Move slider switch into center position. Wait a couple of seconds.

Please Note: If you move the slider switch from down to up in one motion it sets the two limits in the same position. Continued on Page 2

If you encounter any difficulties installing or servicing your Targa screen, call your dealer or Draper, Inc. Spiceland, Indiana, U.S.A., telephone (765) 987-7999 or fax (765) 987-1689.

Case Dimensions/Installation Diagrams

Wall Mounted

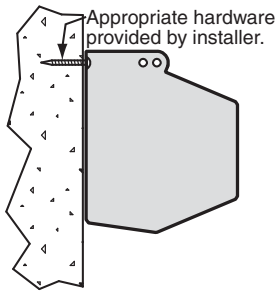

Suspended

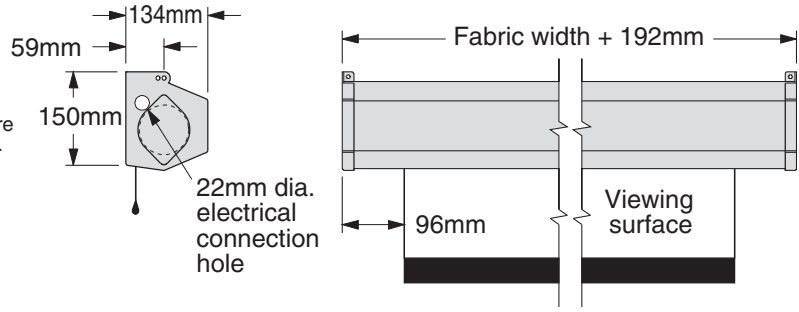
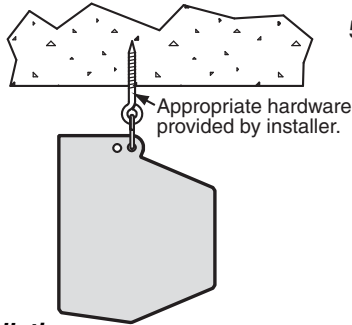

Methods of Installation

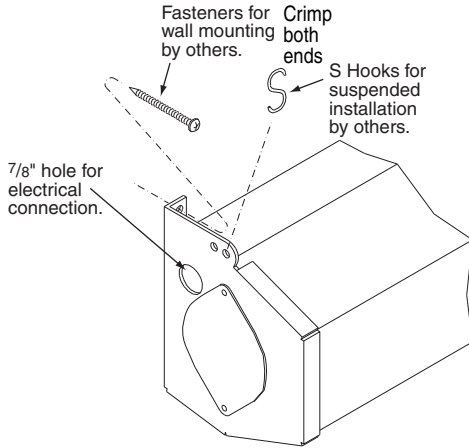

Wiring Diagrams—220V Motor and Quiet Motor

Please Note: Do not wire motors in parallel.

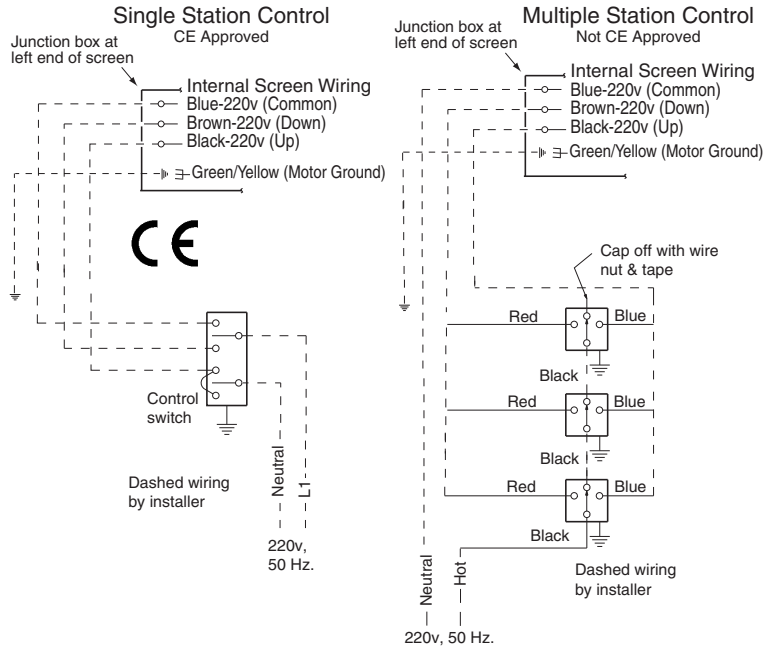

Optional Ceiling Opening Trim Kit (Dims-Side View)

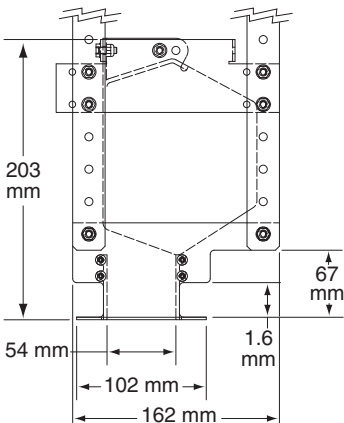

ILT Limit Adjustment Continued from Page 1

- ④ Set the slide switch to the higher position. Move the viewing surface to the desired upper limit by pressing and holding the UP button on the wall switch.
- ⑤ Return the slide switch to the center position to return to normal operation.
- ⑥ To set the viewing surface to an alternate format position, move the viewing surface to the desired position and press the STOP button. Press and hold STOP for at least three seconds to record the position.

Please Note: Pressing and releasing the UP button on the switch will move the screen to its upper limit. Pressing and releasing the DOWN button will move the screen to its lower limit.

While the motor is in motion, pressing STOP for less than two seconds will stop the viewing surface at its present position.

Once the motor is stopped, pressing the STOP button will move the viewing surface to its alternate format position.

Pressing and holding the STOP button, when the motor is at rest or in motion, for at least three seconds will record a new alternate format position.

POSITION	FUNCTION
DOWN	Set LOWER limit
UP	Set UPPER limit
CENTER	Normal Operation

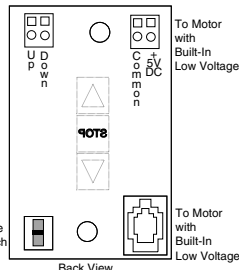

Wiring Diagrams—220V Motor and Quiet Motor with Built-in Low Voltage Controller

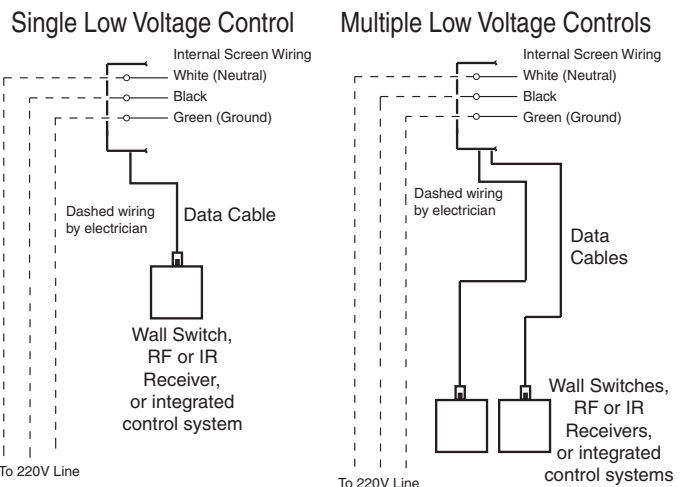

Wiring Diagrams—Plug & Play 220V Motor with Built-in Low Voltage Controller

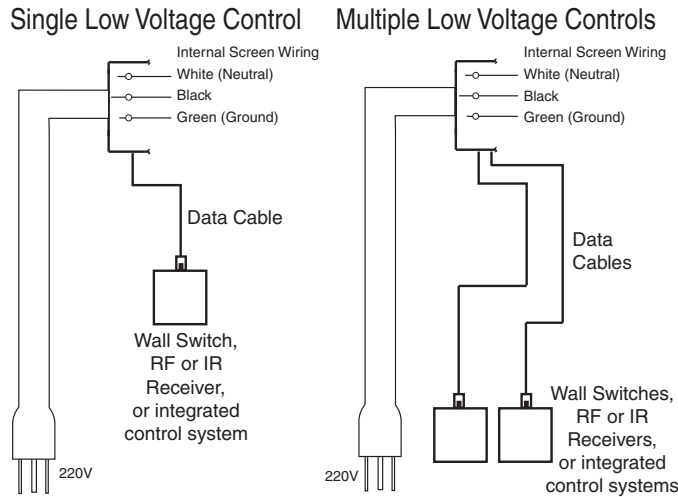

External Low Voltage and Wireless

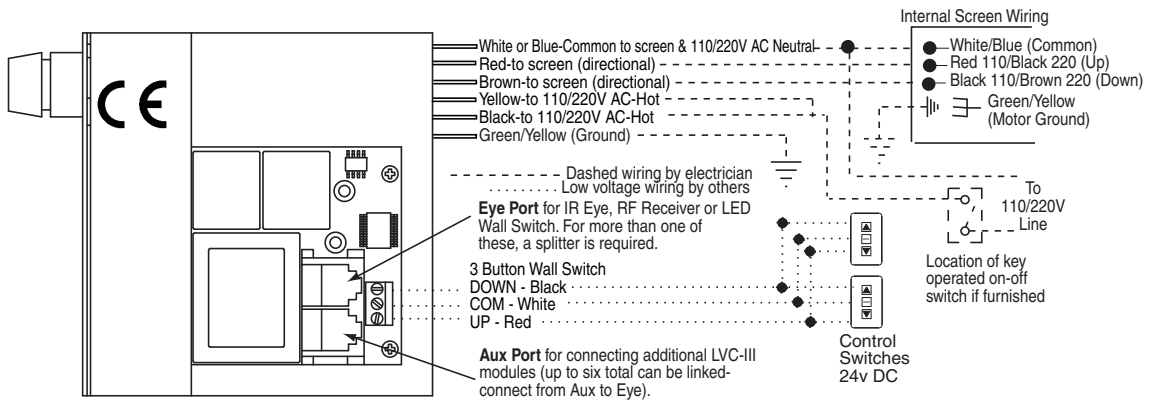

Two-Way Serial Communication (RS232) with MC1

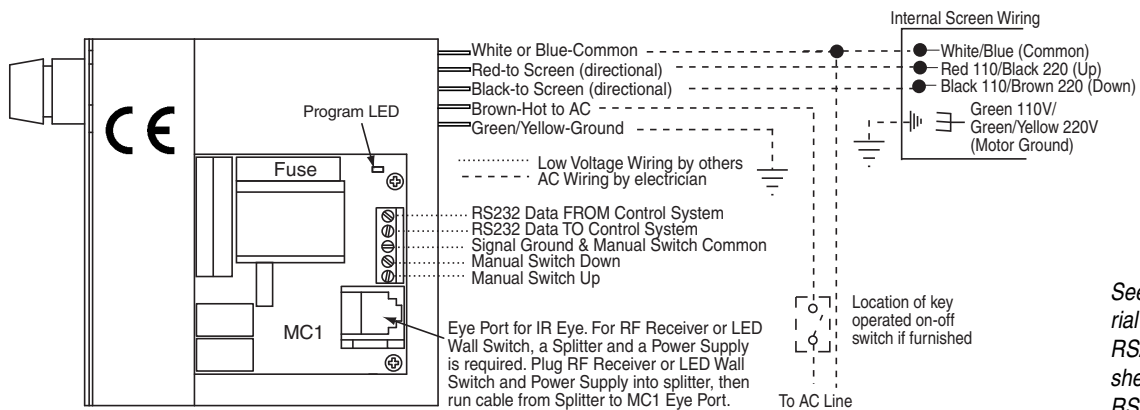

See separate Serial Communication-RS232 Instruction sheet for enabling RS232 with the MC1.